

Time: 3 hours Maximum Marks: 300

READ THE INSTRUCTIONS CAREFULLY

GENERAL

- This sealed booklet is your Question Paper. Do not break the seal till you are told to do so.
- Immediately after breaking the seal of the booklet, verify that the booklet contains **23 pages** and that all the **16 questions** along with the options are legible. Report immediately about any missing or torn sheet in this booklet and ask for a replacement of the booklet from the invigilator. No replacement will be allowed after 15 minutes of the starting of the examination.
- Write your Name, Roll Number, JEE (Advanced) 2022 Rank and other details in the space provided and nowhere else. No distinctive / identification mark of any type is to be put anywhere else in this booklet.
- Answers are to be written only in the booklet and within the space provided beside / below each Question and nowhere else. Answers written in non-designated place will not be evaluated.
- Blank spaces are provided within this booklet for rough work.
- Do not deface this booklet or detach or mutilate any sheet from the booklet. Such acts lead to disqualification.
- The question paper has five sections.
- **All the questions are compulsory.**

Total Marks Obtained:

In Numbers:

In words: _____

Signature of the Examiner with date

Signature of the Scrutinizer with date

NAME: _____

ROLL NO: _____

JEE (ADVANCED) 2022 RANK: _____

CATEGORY: _____

CATEGORY RANK (IF APPLICABLE):

EXAMINATION CENTRE:

I HAVE READ ALL THE INSTRUCTIONS AND SHALL ABIDE BY THEM

Signature of the Candidate

Signature of the Invigilator after verification of identity and other details



This Page is kept blank intentionally

DO NOT WRITE ON THIS PAGE



SECTION A: Architectural Awareness (Maximum Marks: 60)

This section contains **FOUR** questions. Question 1 carries **30 marks**, Questions 2, 3 and 4 carry **10 marks** each. There is **NO** negative marking.

Q.1. This section contains **15 multiple choice questions**. Each question has four options, out of which **ONLY ONE** is correct. Mark the correct option with a tick mark.

(15 x 2=30 Marks)

(i) Which of the following bridges is laid over a sea?

Godavari Bridge, Andhra Pradesh

Pamban Bridge, Tamilnadu

Howrah Bridge, West Bengal

Mahatma Gandhi Setu, Bihar

(ii) In 2021, _____ annual festivity got inscribed on the representative list of Intangible Cultural Heritage of Humanity by UNESCO.

Makara Sankranti

Ganesh Chaturthi

Durga Puja

Chhath Puja

(iii) Which of the following historic gateways is sharing an edge with a water body?

Charminar, Hyderabad

India Gate, New Delhi

Rumi Darwaza, Lucknow

Gateway of India, Mumbai



- (iv) Given below is an image of a residential building located in Switzerland, designed by Architect Mario Botta. Amongst the following, which kind of a drawing technique does it correspond to?

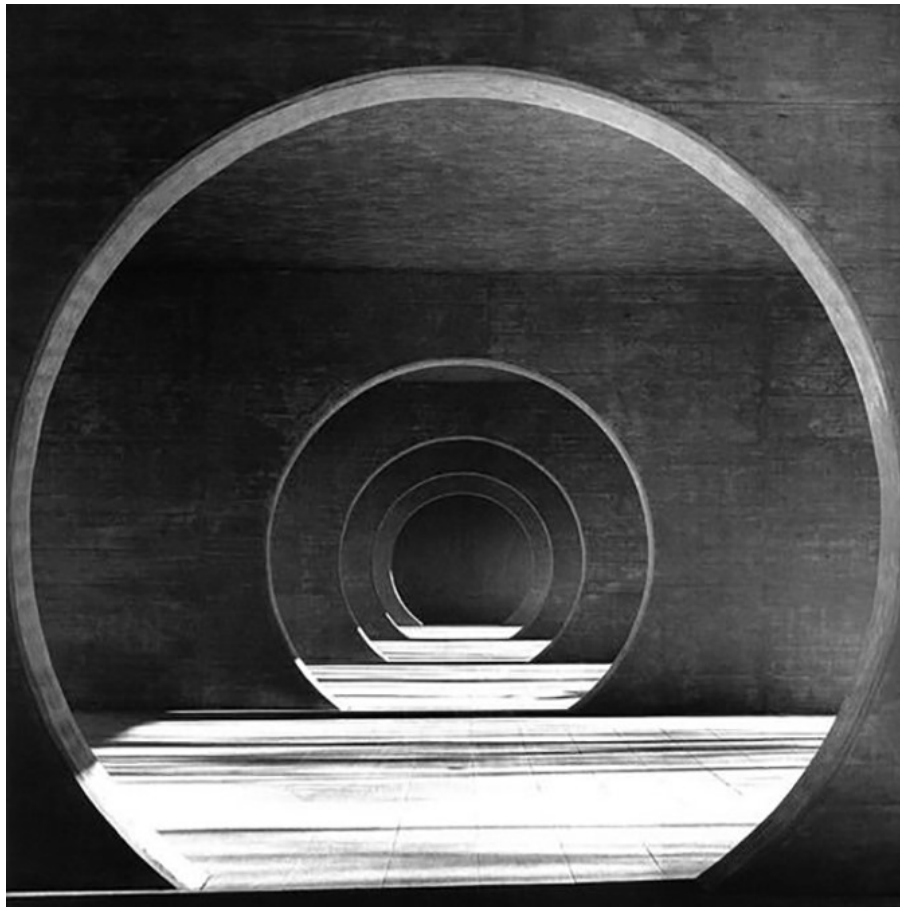

One Point Perspective

Isometric View

Axonometric View

Bird's Eye View

- (v) Which architect has designed the building 'Church of Light', located in Japan?

Moshe Safdie

Fumihiko Maki

Zaha Hadid

Tadao Ando



- (vi) Refer to the graphical representation of timber, shown in figure 1. Which material does the graphical representation shown in figure 2, indicate?

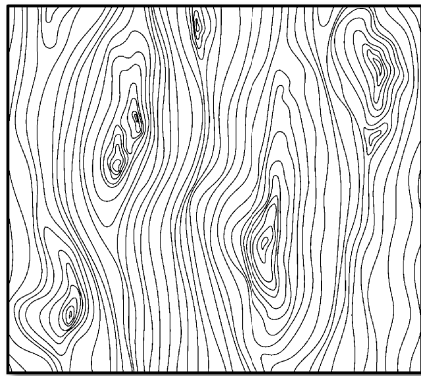

Figure 1

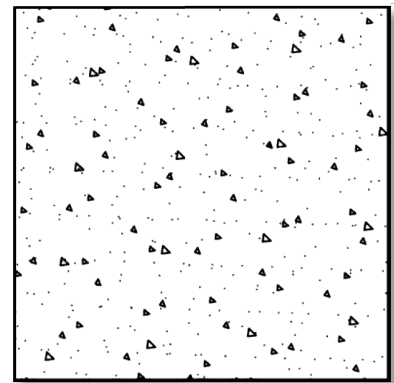

Figure 2

Thermocol

Concrete

Steel

Brick

- (vii) In the figure given below, the area of square MNOP is twice that of the square ABCD. The triangle AOR is a right angled triangle having $AO = RO$. The area of the triangle AOR is _____ times the area of square ABCD.

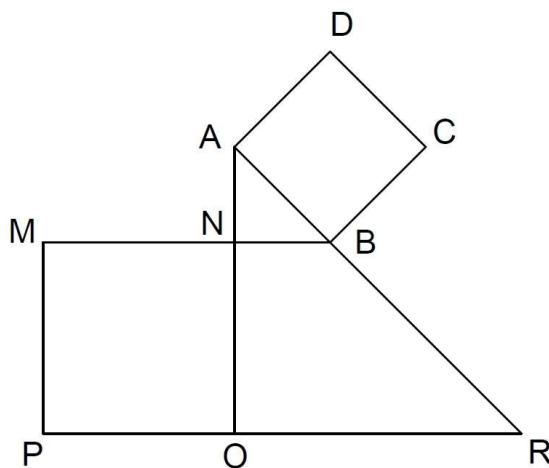

1.75

2.25

3.0

2.5

(viii) Read the following statements and choose the correct options.

Statement A: Parapet is a type of window

Statement B: Pile is a type of foundation

- Both the statements A & B are Correct
- Both the statements A & B are Wrong
- The statement A is Correct but statement B is Wrong
- The statement B is Correct but statement A is Wrong

(ix) C.B.R.I. at Roorkee stands for _____.

- Central Bureau of Residential Information
- Centre for Building Rehabilitation Initiative
- Central Building Research Institute
- Centre for Brick Research Institute

(x) 'Lux' is a unit of _____.

- Solar Radiation
- Sensitivity of Light
- Indoor Air Quality
- Intensity of Illumination

(xi) Statue of which famous personality is called 'Statue of Unity'?

- Mahatma Gandhi
- Dr. B. R. Ambedkar
- Sardar Vallabhbhai Patel
- Indira Gandhi



- (xii) A circular hole is drilled through the length of a Cuboid as shown conceptually in the figure given below. An inclined plane cuts the solid into two parts at an angle of 30° with the direction of length. What will be the shape of the hole, while seeing in normal direction to the cutting plane?

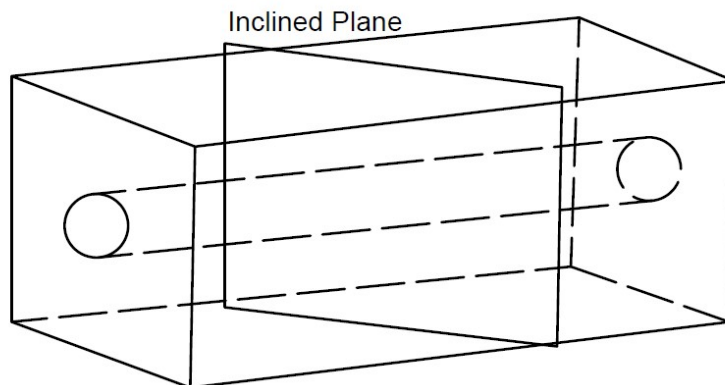

- | | |
|--------------------------------------|-----------------------------------|
| <input type="checkbox"/> Elliptical | <input type="checkbox"/> Circular |
| <input type="checkbox"/> Rectangular | <input type="checkbox"/> Rhombus |

- (xiii) The proposed Bullet train project of India, connects Mumbai with which Indian city?

- | | |
|------------------------------------|------------------------------------|
| <input type="checkbox"/> Bengaluru | <input type="checkbox"/> Ahmedabad |
| <input type="checkbox"/> Hyderabad | <input type="checkbox"/> Panaji |

- (xiv) A triangular prism has equal sides of 3 units each and a length of 10 units. Calculate the surface area of the prism.

- | | |
|--|--|
| <input type="checkbox"/> $90 + \frac{9\sqrt{3}}{2}$ square units | <input type="checkbox"/> $90 + \frac{7\sqrt{3}}{4}$ square units |
| <input type="checkbox"/> 90 square units | <input type="checkbox"/> $30 + \frac{9\sqrt{3}}{2}$ square units |

- (xv) A circular plate consists of a metallic disc and a glass ring as shown in the figure 1. The diameter of the metallic disc is 16cm and the thickness of the glass ring is 2cm. The circular plate is then kept horizontally, 3cm below the point source of light (P). The light will cast a shadow on a screen (R) placed 3cm below the circular plate. Refer to the figure 2. What is the area of the ring of light that is being cast on the screen (R)?

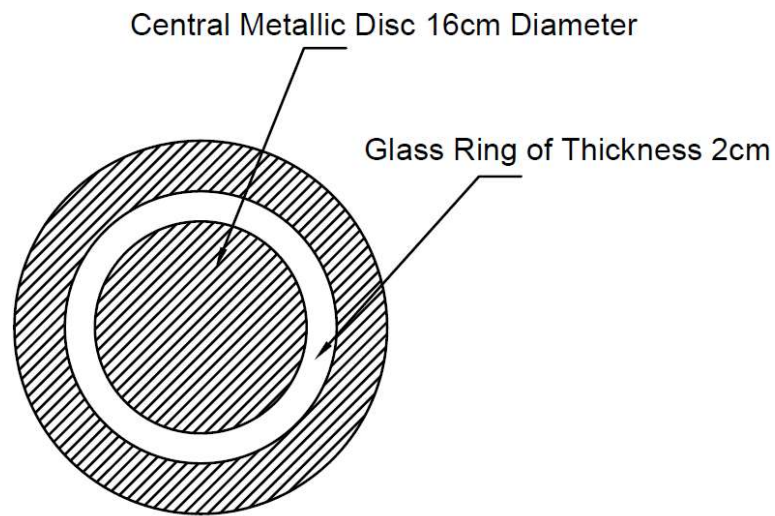

Figure 1

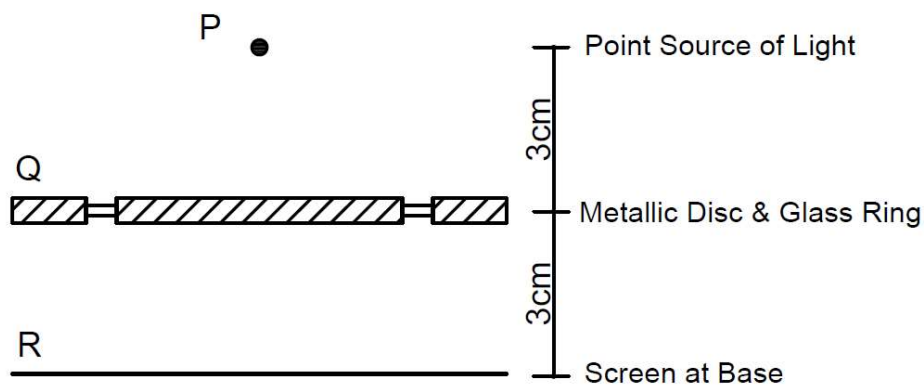

Figure 2

$144\pi \text{ cm}^2$

$132\pi \text{ cm}^2$

$128\pi \text{ cm}^2$

$116\pi \text{ cm}^2$

Q.2 Match the famous architects in column I with their renowned projects in column II.
(5 x 2 = 10 Marks)

Column I

Column II

(A) Charles Correa

(P) IIM Bangalore

(B) B V Doshi

(Q) Capitol Complex, Chandigarh

(C) Bimal Patel

(R) Central Vista, New Delhi

(D) Raj Rewal

(S) Dakshina Chitra, Chennai

(E) Le Corbusier

(T) Bharat Bhawan, Bhopal

(U) Parliament Library, New Delhi

Q.3 Match the material in Column I with the craft in Column II.
(5 x 2 = 10 Marks)

Column I

Column II

(A) Stone

(P) Origami

(B) Paper

(Q) Embroidery

(C) Glass

(R) Carving

(D) Fabric

(S) Carpentry

(E) Metal

(T) Etching

(U) Filigree

Q.4 Refer to the following sketch of St. James' Church, Delhi. Match the numbers mentioned in Column I (highlighted in the sketch) with corresponding building elements in Column II. (5 x 2 = 10 Marks)



Column I

(A) i

(B) ii

(C) iii

(D) iv

(E) v

Column II

(P) Column

(Q) Pediment

(R) Plinth

(S) Dome

(T) Architrave

(U) Arch

SECTION B: Geometrical Drawing (Maximum Marks: 60)

- This section contains **THREE (03)** questions. Each question carries **20** marks.

Q.5 Given below is a figure representing a geometrical frame composed of few squares of different sizes, out of which, three small squares are hatched. The respective proportionate dimensions are indicated. You are required to do the following tasks. Draw your answers in the appropriate unhatched spaces.

- Divide the unhatched portion in Square A into two equal parts having same shape and size.
- Divide the unhatched portion in Square B into three equal parts having same shape and size.
- Divide the unhatched portion in Square C into four equal parts having same shape and size.
- Divide the unhatched portion in Square D into eight equal parts having same shape and size.

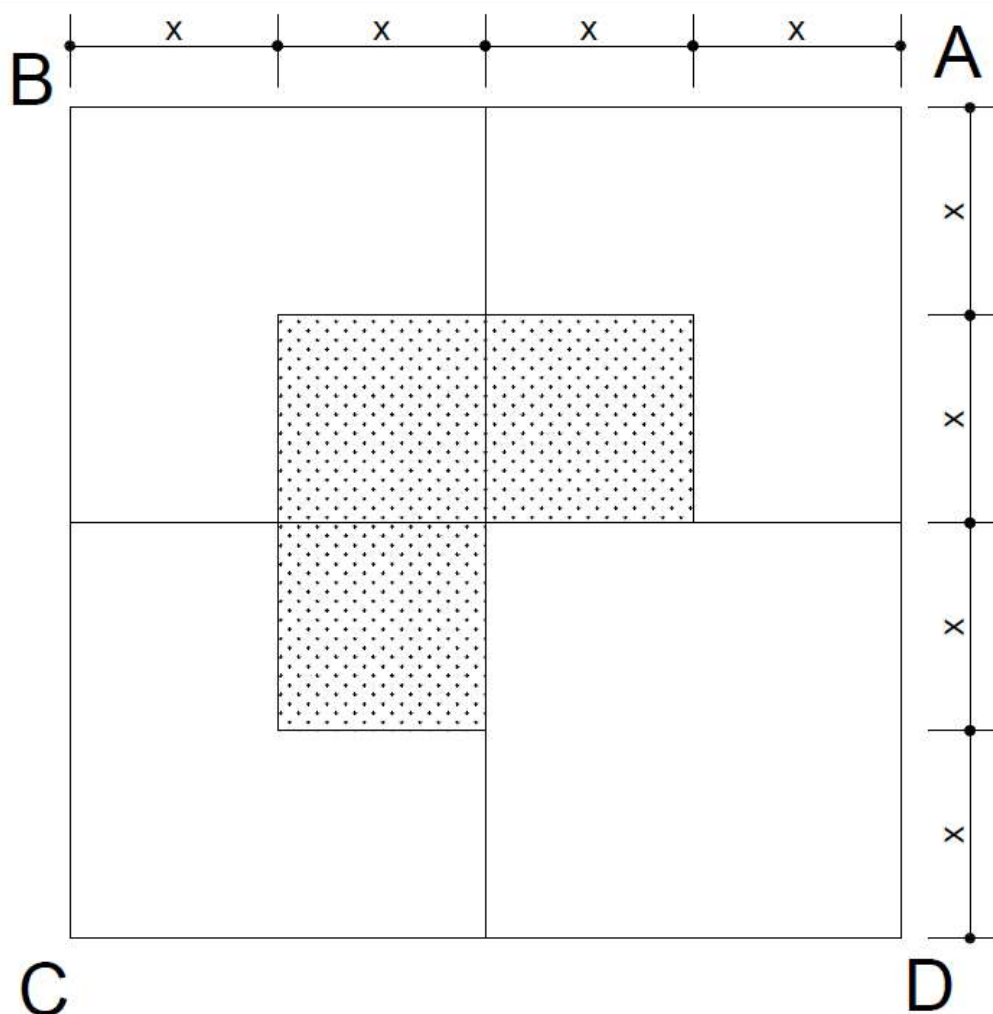

Q.6 Generate the geometric pattern by reflecting the two dimensional hatched portion, first, about the axis AB and then the resultant figure about the axis XY. Draw the final resultant reflection pattern in the space provided in the following figure.

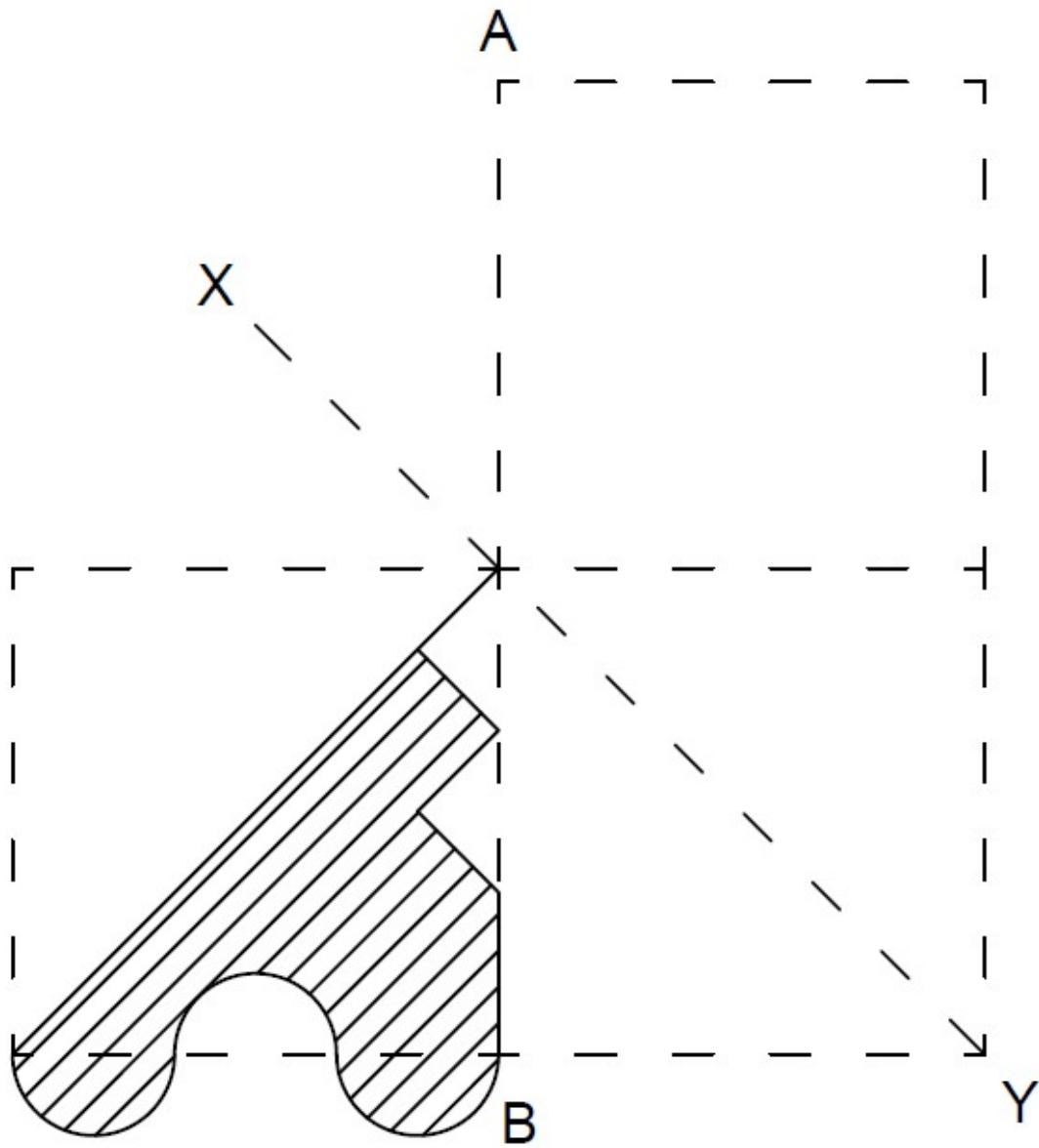

- Q.7 See the figure below showing a section of a church street composed in a frame. You are required to enlarge the same by 1.5 times and draw the image maintaining its proportions.

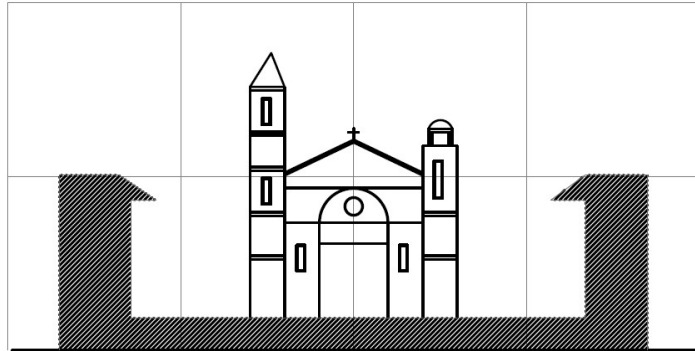

SECTION C: 3D Perception (Maximum Marks: 60)

- This section contains **THREE (03)** questions. Each question carries **20** marks.

Q.8 Imagine that you are provided with six equal sized sticks. By using these sticks one can easily develop two equilateral triangles as shown in the figure. By using the same six sticks, generate and draw a three dimensional form having four triangular faces in the space provided below.

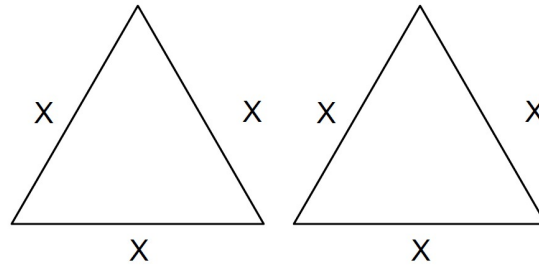

Q.9 The surface development of a three dimensional object is given in the figure. Develop its isometric view in the direction of X in the space given below.

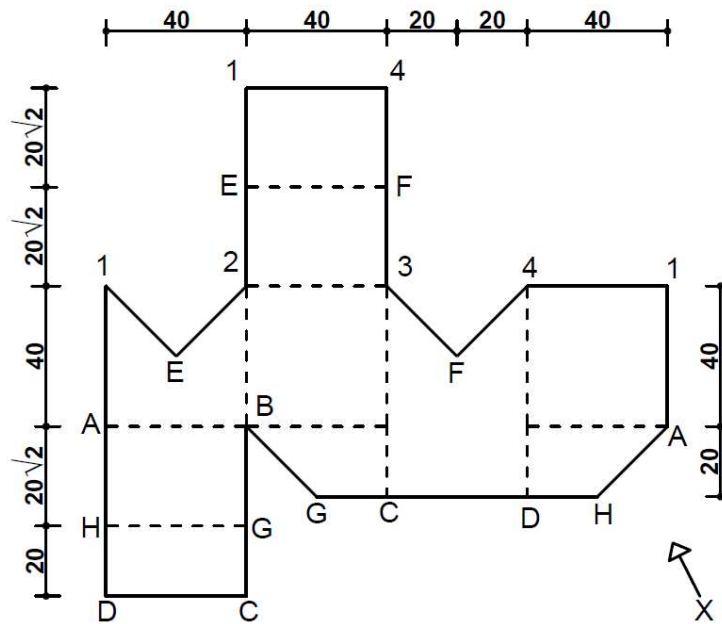

Q.10 The generator plane and the axis of rotation are given in the figure. Sketch the three dimensional form, that can be obtained by one complete rotation of the generator about the axis.

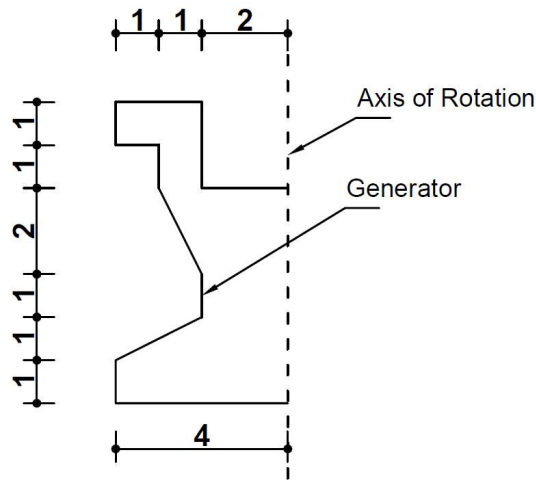

SECTION D: Imagination and Aesthetic Sensitivity (Maximum Marks: 60)

- This section contains **THREE (03)** questions. Each question carries **20** marks.

Q.11 Design a wallpaper for the home screen of the mobile phone shown below. Use only lines in three different colours, which are red, yellow and blue. You are required to play with the density of lines to create impressions such as depth, distance, straightness and curve.

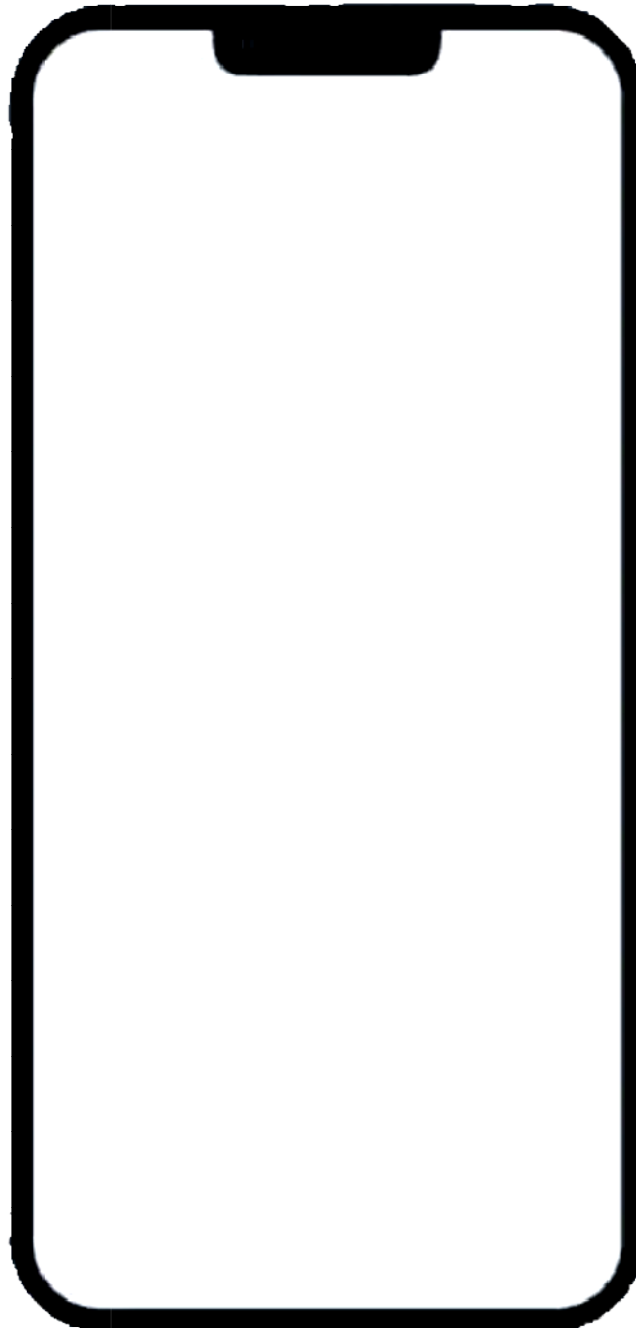

- Q.12 Nature is the best teacher. Simply by observing trees, flowers, organisms and natural elements present in the surroundings, one can have an understanding of form, function and aesthetics. Designers and architects often take inspiration from nature to design products, buildings and systems. Based on your experiences and memories, translate the understanding of nature in the design of a chair. Mention briefly about your inspiration and the element selected from nature, in the space provided for write-up.

Space for write up



Q.13 Using only triangles and circles, create a two dimensional composition by selecting any one of the following three themes:

- a) Displacement
- b) Asymmetry
- c) Scale

Mention the theme selected by you. Use only black pencils.

Space for write up



SECTION E: Freehand Drawing (Maximum Marks: 60)

- This section contains **THREE (03)** questions. Each question carries **20** marks.

Q.14 The outline of a room interior is provided below. Imagine it as your hostel room and draw the interior elements highlighting furniture, decoration and associated activities, along with human figures.

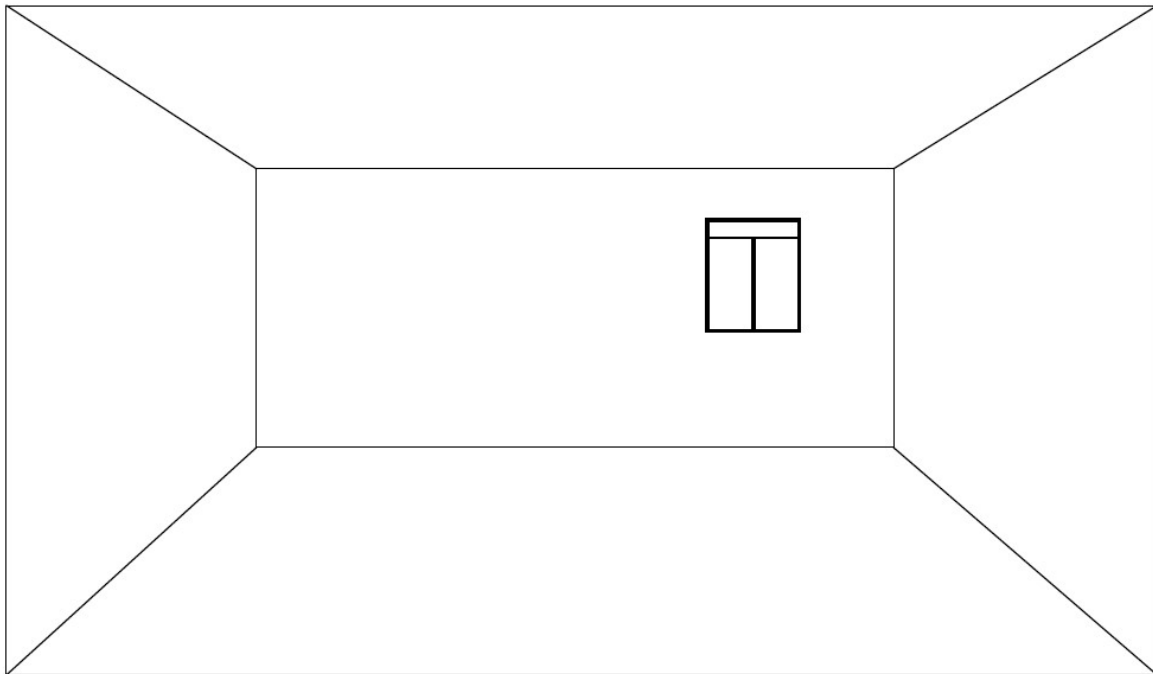

- Q.15 Imagine there is a glass bowl placed on a table in front of you. It is filled with fruits such as apples, pineapples, bananas and grapes. Apart from these, you may consider other varieties of fruits as well. Sketch this using black pencil only.

- Q.16 Addressing the challenges imposed by the COVID 19, create a scene of a restaurant entrance, highlighting the following details:
- Facade showcasing relevant characteristics of a restaurant operating in a pandemic
 - The security guard in COVID appropriate uniform, monitoring the social-distancing, safety and hygiene protocols.

END OF THE QUESTION PAPER



DO NOT WRITE ON THIS PAGE**Section-wise Distribution of Marks**

Sections	Question No.	Page No.	Maximum Marks	Marks Obtained
Section A (Architectural Awareness)	Q. 1	03-08	30	
	Q. 2	09	10	
	Q.3	09	10	
	Q.4	10	10	
Section B (Geometrical Drawing)	Q.5	11	20	
	Q.6	12	20	
	Q.7	13	20	
Section C (Three Dimensional Perception)	Q.8	14	20	
	Q.9	15	20	
	Q.10	16	20	
Section D (Imagination and Aesthetic Sensitivity)	Q.11	17	20	
	Q.12	18	20	
	Q.13	19	20	
Section E (Freehand Drawing)	Q.14	20	20	
	Q.15	21	20	
	Q.16	22	20	
TOTAL MARKS			300	